



Fonderie Sime S.p.A. - Via Garbo, 27 - 37045 Legnago (VR) - www.sime.it
Tribunale Verona 13531 - R.E.A. VR 171357 - C.C.P. 19423375 - N° Mecc. VR 014435
Capitale Sociale Euro 5.521.200 int. versato - Codice Fiscale/Partita IVA n. IT 01275930236

Comfort Ambiente - Via Garbo, 27 - 37045 Legnago (VR)

Tel +39 0442 631111 - Fax Servizio Commerciale: Italia +39 0442 631291 - Estero +39 0442 631293

Fax Servizio Tecnico +39 0442 631292 - Fax Ufficio Acquisti +39 0442 631292 - Fax Amministrazione +39 0442 631336

8115022 VERA HE 30

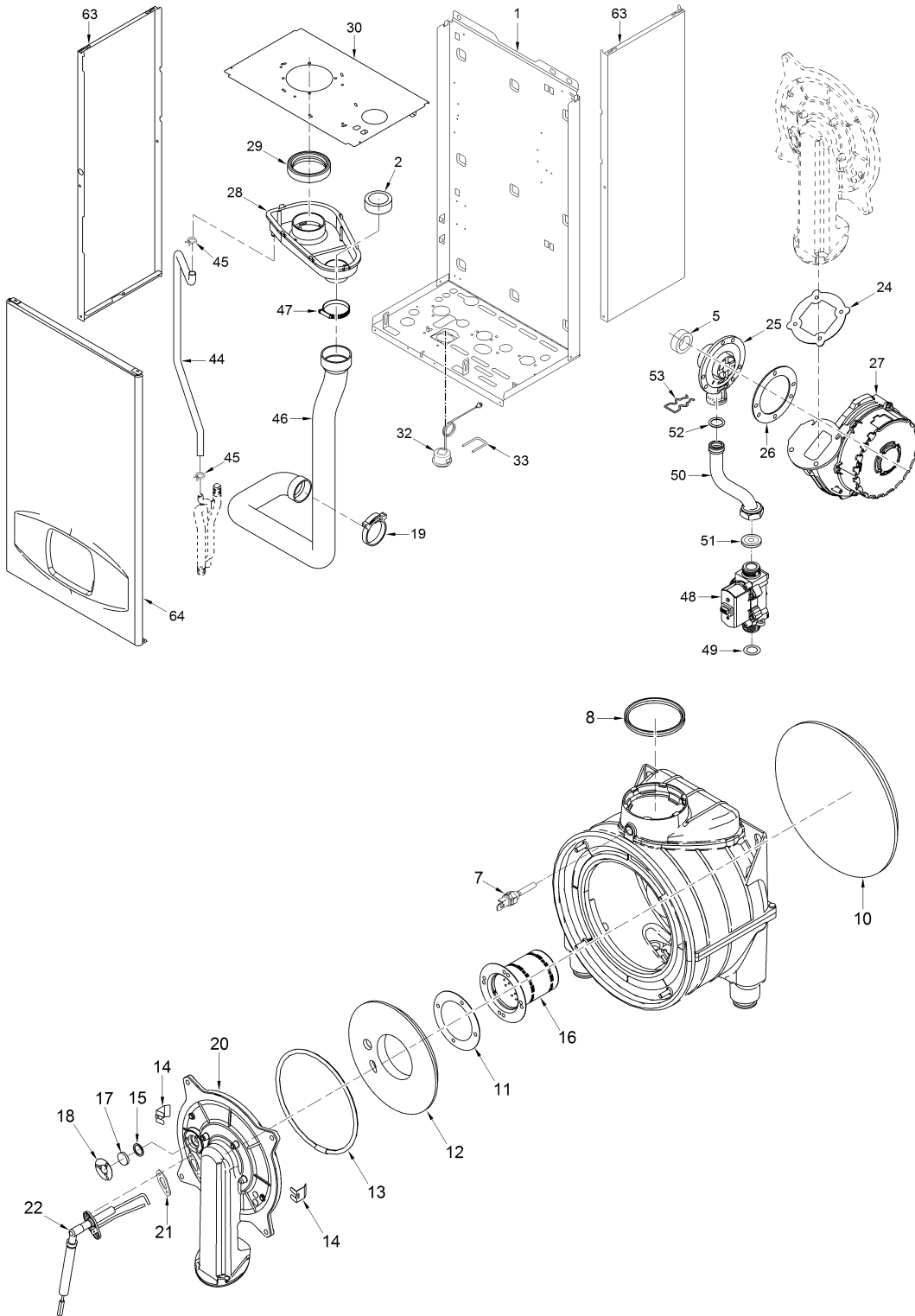

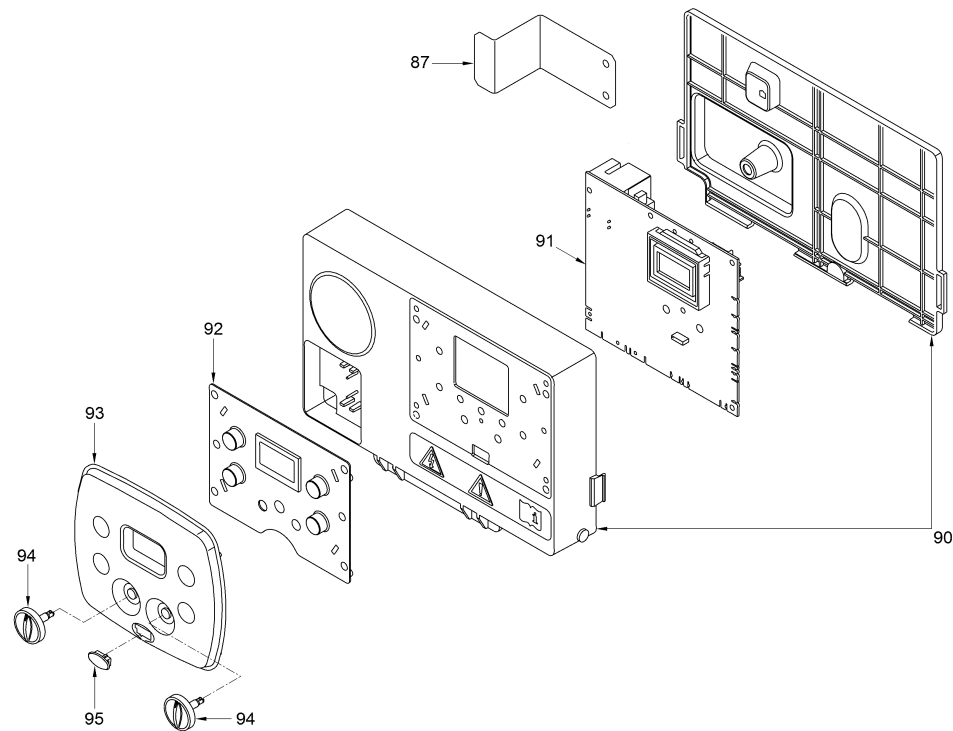
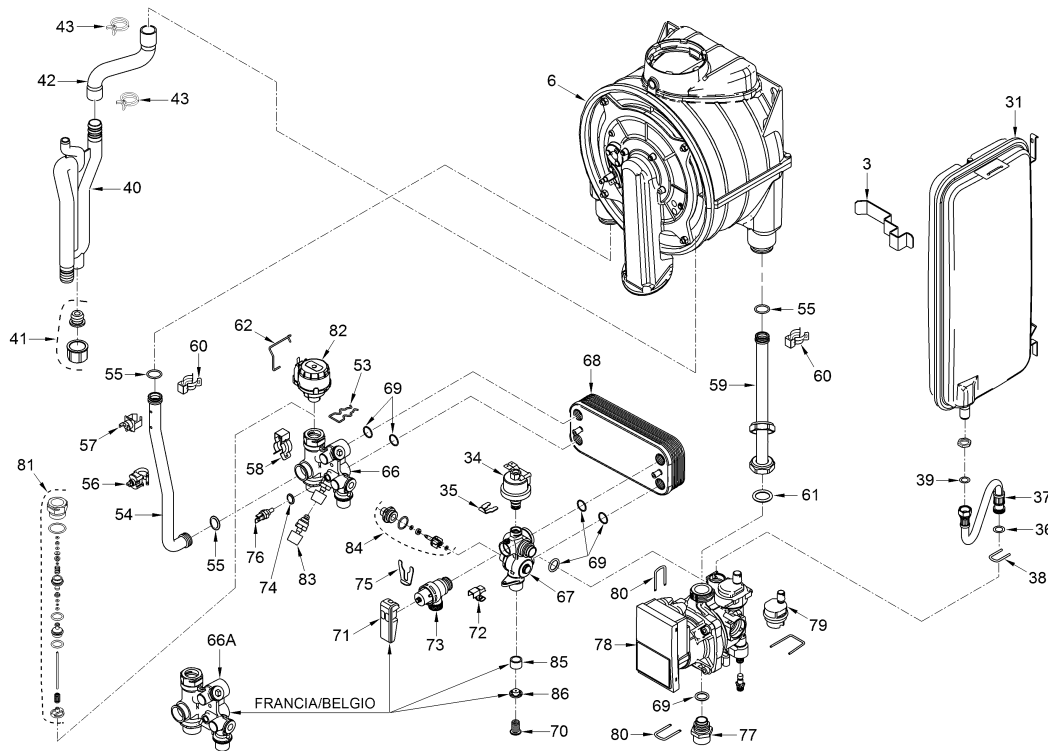

Position	Code	Description	Where used	Advised parts	Price list
	6211796	Ignit.-ionis.elect.+ ûasket kit		B	29.58
001	6264560	Boiler fixing bracket			14.64
003	6321417	Bracket			0.0
005	6001165	Tube reduction collar	TO SN 4905301400		4.72
006	6278920	Main exchanger body			371.32
007	6277130	Probe NTC D.4X40		A	17.74
008	6326949	Smoke outlet gasket ø80 mm		C	6.34
010	6326940	Rear insulation + springs			21.75
011	6326942	Gasket for burner flange		C	2.55
012	6326943	Front insulation		C	28.75
013	6326945	Fibre sealing cord		C	19.52
014	6326944	Insulation hook			1.28
015	6326948	Glass gasket			1.28
016	6278372	Premix burner			38.19
017	6326946	Glass			3.18
018	6326947	Fixing glass plaque			1.91

019	2051252	Hose clamp Ø 53-57		0.0
020	6278923	Main door/air-gas hose exchange		37.08
021	6326950	Gasket for ignition electrode	C	1.24
022	6221673	Ignition-ionisation electrode		21.36
024	6174816	Gasket for fan flange		1.17
025	6274316	Air/gas mixer		9.27
026A	6028716	Gasket for fan/mixer	C	0.0
027	6261412	Fan	A	199.84
028	6278703	Smoke chamber		12.58
029	6248855	P.C. inlet/outlet smokes gasket	C	5.91
030	6291150	Upper protection shield		12.02
031	5183729	Rectang. expans.vessel 9 l. 3/8	C	47.94
032	6146101	Hydrometer	B	17.74
033	6226628	Hydrometer Fixing spring		1.17
034	6273612	Water pressure transducer		48.48
035	6226639	Spring clip		1.14
036	6226476	ORing diam.15x2	C	0.66
037	6017405	Flexible pipe M.F. 3/8" L=300		6.47
038	6226643	Pipe fixing spring		0.56
039	2030226	Gasket Ø 10,2x14,8x2	C	0.61
040	6277211	Water trap		11.26
041	5171635	Cap + gasket for water trap kit		10.61
042	6034155	Condensate drainage pipe		5.91
043	2051123	Clamp diam. 24,2		0.61
044	1010215	Rubber pipe dia. 15x2,5		11.81
045	2051120	Clamp diam. 17,3		1.17
046	6001173	Air intake pipe 54		22.66
047	2051203	Hose clamp Ø 40-60		8.2
048	6243838	Gas valve	A	67.0
049	2030249	Gasket Ø 24x17x3		0.61
050	6277456	Pipe connecting gas valve-mixer		10.02
051	6050471	Nozzle 530		6.88
052	6226477	Rubber gasket OR Ø 17x3	C	0.43
053	6226636	D.H.W. elektrovalve fix.spring		1.14
054	6227486	Flowing pipe to C.H. system		0.0
055	6226412	O-ring 3068	C	1.17
056	6231372	Temperature sensor	A	10.59
057	6146729	100°C safety stat	A	8.03
058	6226601	Spring for heat exchanger conne		2.36
059	6227548	Return pipe from C.H. system		9.5
060	6226619	Spring for heat exchanger conne		4.72
061	2030267	Piracriten gasket Ø 30x17x2		0.72
062	6226638	Divertor valve motor spring cli		2.18
063	6304480	casing left/right side panel		29.5
064	6325072	Casing front panel		33.95
066	6265870	C.H. flow manifold		61.3
067	6265832	C.H. return manifold		27.32
068A	6265656	12 plate-type heat exchanger	C	62.0
069	6226475	ORing diam.18,64x3,53	C	0.29
070	6222003	D.H.W. filter	C	0.29
072	6131440	Flowmeter sensor	A	8.91
073	6040225	Pressure relief valve 1/2" 3 ba	C	3.9
074	6022010	Sensor gasket		1.17
075	6226645	Spring clip		1.09
076	6231351	Plunged sensor	A	9.47
077	6120560	Pump nipple 3/4"		9.84
078	6272369	Modulating circulating pump	B	217.87
079	6013182	Automatic air vent	C	15.37
080	6226644	Spring clip for rotating connec		0.56
081	6319645	Three-way plates group	B	14.76
082	6087332	Motor for diverting valve	B	28.98
083	6319639	Filling cock	C	20.06
084	6319644	Flowmeter group	B	13.38
087	6321415	Support bracket		0.0
090	6304720	Control panel		25.5
091	6324950	Main P.C.B		142.0
092	6305130	Rubber button		6.33
093	6304857	Interface panel		10.82
094	6290150	Knob Ø 25		1.85
095	6305140	Rubber cap		0.99
700	5204000	Complete control panel	TO SN	0.0
703	6323875	6 pole cable connector CN12		11.47
704	6323876	4 pole cable connector CN14		2.41
707	6281534	Gaskets kit	C	22.47
708	6319695	Murelle-Format-.....o-ring kit	C	8.28
709	6319700	Springs / clamps kit DIN		16.39
710	6325671	9 pole cable connector CN1		0.0

711	6325674	6 pole cable connector CN2	TO SN		10.27
712	6325673	14 pole cable connect. CN15+CN5			12.36
713	6325669	Pump-fan 4 pole connect. CN13	TO SN		10.88
715	6316259	5 pole cable connector		B	11.81
716	5204002	Complete control panel	FROM SN		0.0
717	6329449	4 pole cable connector CN13	FROM SN		0.0
718	6329459	6 pole cable connector CN2	FROM SN	B	11.33
719	6034130	Drain water flexible pipe			7.73
720	6211795	Peephole kit		C	0.0

- A = Spare parts for minimum fittings
- A+B = Spare parts for basic safety fittings
- A+B+C = Spare parts for extended safety fittings